

Guardian

Liquid Eliminator and Analyzer Shutoff



The Welker® Guardian protects analyzers from contamination and damage by blocking liquids from gas samples and preventing the flow of liquid to the analyzer.

Features

- 2-stage protection for analyzers
- Liquid-eliminating chamber
- Positive shutoff with the presence of liquid in the equipment
- Sight glass for instant visual confirmation of flow status
- Stainless steel construction

Benefits

- Optimizes profitability by protecting sensitive equipment from liquid damage
- Combines two innovative Welker® products from the Analyzer Grade Gas Conditioning product line
- Stainless steel construction provides long life and superior resistance against corrosion
- Compact size
- Quick and easy installation
- Simple maintenance



SPECIFICATIONS

GUARDIAN LIQUID ELIMINATOR AND ANALYZER SHUTOFF

GUARDIAN

Materials of Construction	304 Stainless Steel, 316/316L Stainless Steel, Aluminum, Glass, LEXAN™, Teflon®, Viton®
Drain Connection	¼" FNPT
Inlet Connection	¼" FNPT
Outlet Connection	⅛" FNPT
Filtration	Nominal 25 Micron Internodal Distance
Operating Pressure	1000 psig MAOP @ -20 °F to 290 °F

STANDARD PART NUMBER

GUARDIAN LIQUID ELIMINATOR AND ANALYZER SHUTOFF

ALSLE

For custom options, choose **Plus Welker™**.



Customer Inspired. Welker Manufactured.

Collaborate with us to create a custom product unique to your application.

DIMENSIONS

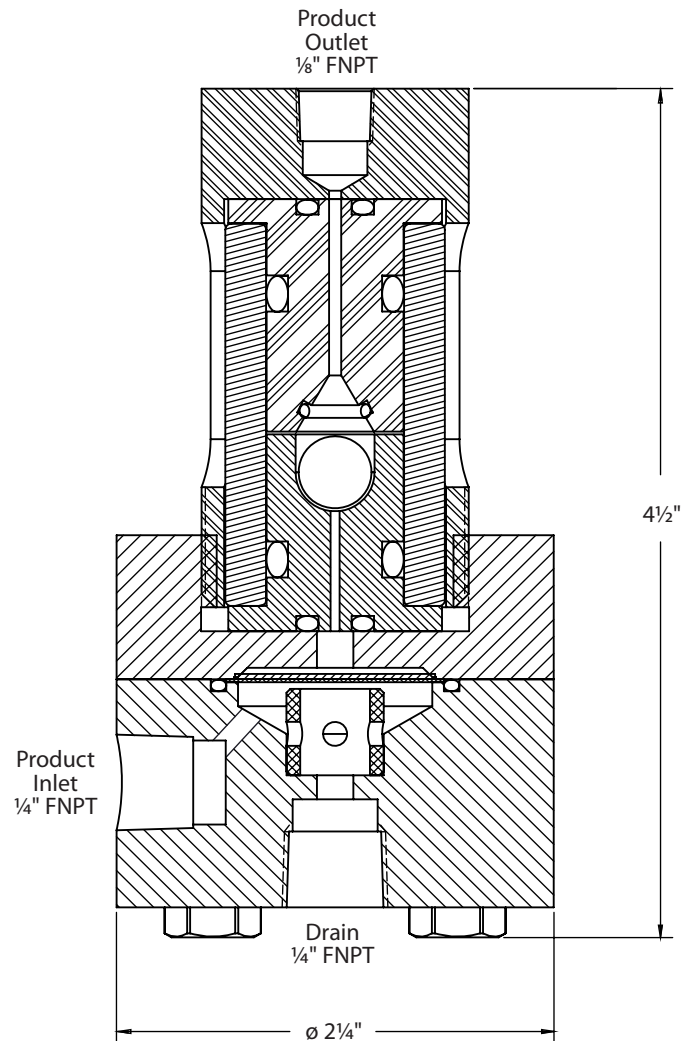

Weight and/or dimensions are approximate.
Specifications subject to change without notice.



13839 WEST BELLFORT STREET SUGAR LAND, TEXAS 77498 | 281.491.2331 | sales@welker.com | WELKER.COM
©2017 Welker, Inc., All Rights Reserved. Welker®, W Welker®, W Logo, WelkerScope®, Welker Jet®, and OdorEyes® are registered trademarks owned by Welker, Inc.